

Installation Guide

5-Port or 8-Port Gigabit Ethernet Easy Smart Managed Essentials Switch Model GS305E and GS308E

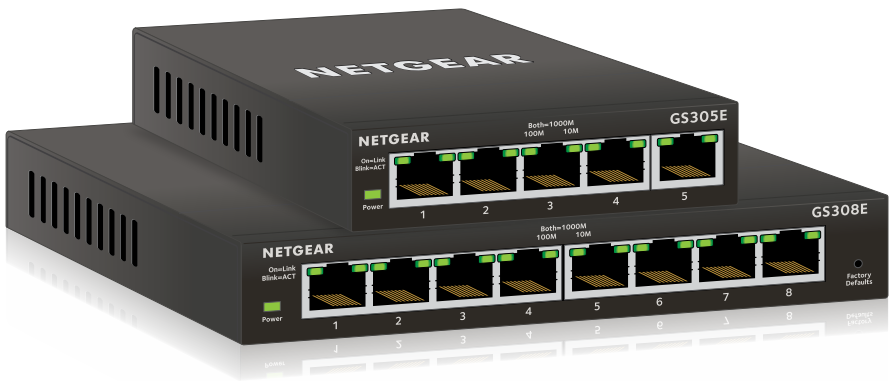

Package contents

- Model GS305E or GS308E Easy Smart Managed Essentials Switch
- Power adapter (varies by region)
- Installation Guide

1. Register the switch

Registration is required for warranty activation and support. For more information, visit netgear.com/about/warranty.

1. From a computer or mobile device that is connected to the Internet, visit my.netgear.com.
2. Log in to your NETGEAR account.
NOTE: If you don't have a free NETGEAR account, you can create one. The Your Registered Products page displays.
3. Click the **REGISTER NEW PRODUCT** button.
4. In the **SERIAL NUMBER** field, type the serial number of your switch. The serial number is 13 digits long. It is printed on the switch label.
5. From the **PURCHASE DATE** menus, select the date that you purchased the switch.
6. Click the **REGISTER** button.

Your switch is registered to your NETGEAR account. A confirmation email is sent to your NETGEAR account email address.

2. Connect the switch

Sample connections

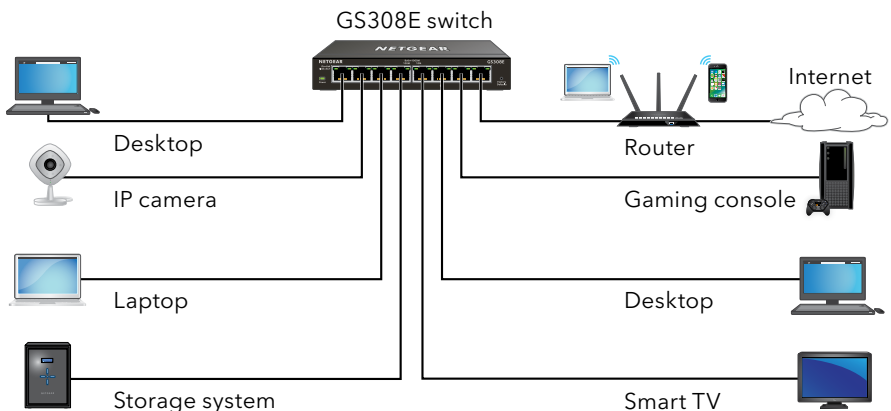

1. Connect network devices to the ports on the switch.
2. Connect an RJ-45 port on the switch to a network.

NOTE: In a small office or home office network, connect the switch to the LAN port of a router that, in turn, is connected to a modem.
3. Power on the switch.









This switch is designed for indoor use only. If you want to connect it to a device located outdoors, the outdoor device must be properly grounded and surge protected, and you must install an Ethernet surge protector inline between the switch and the outdoor device. Failure to do so can damage the switch.



WARNING: Before connecting this switch to outdoor cables or devices, see <https://kb.netgear.com/000057103> for safety and warranty information.

3. Check the LEDs

When you connect the power cord to the switch and plug it into an electrical outlet, the LEDs indicate the status:

LED	Description	
Power LED	 The switch is powered on and operating normally.	
	 The switch is starting.	
	 Power is not supplied to the switch.	
Left port LED	Right port LED	Combined, these RJ-45 port LEDs indicate link, speed, and activity.
		1 Gbps link is established. If both LEDs are blinking, the port is processing packets at 1 Gbps.
		100 Mbps link is established. If the left is LED is blinking, the port is processing packets at 100 Mbps.
		10 Mbps link is established. If the right LED is blinking, the port is processing packets at 10 Mbps.

4. Discover the switch's IP address

NETGEAR Easy Smart Managed switches support Universal Plug and Play (UPnP) discovery. You can use your computer's network settings to discover the switch in your network.

Alternatively, you can download the NETGEAR Discovery Tool (NDT), which lets you discover the switch in your network and access the device user interface (UI) of the switch from a Mac, Windows-based, or Linux-based computer.

To install the NETGEAR Discovery Tool, discover the switch in your network, access the switch, and discover the switch IP address:

1. To download the tool, visit netgear.com/support/product/netgear-switch-discovery-tool
Download the Mac, Windows, or Linux version.
2. Temporarily disable the firewall, Internet security, antivirus programs, or all of these on the computer that you use to configure the switch.
3. Unzip the NDT file, and double-click the .exe file to install the program on your computer.
You might see the tool icon appear on your Mac dock, Windows desktop, or Linux desktop.
4. Reenable the security services on your computer.
5. Power on the switch.
6. Connect your computer to the same network as the switch.
7. Open the NDT.
The initial page displays a menu and a button.
8. From the **Choose a Connection** menu, select the network for this switch.
9. Click the **Start Searching** button.
The NDT displays the IP addresses of the switches that it discovers.
10. Click the **ADMIN PAGE** button.

The login page of the device UI displays.

11. Enter the default password that is printed on the switch label.

12. If prompted, enter a new admin password for the switch.

The HOME page displays, and shows the IP address assigned to the switch.

13. Save the password and IP address for future use.

You can now configure and monitor your switch.

! **NOTE:** For more information, see the user manual, which you can download from the NETGEAR Download Center at netgear.com/support/download. The QR code for the NETGEAR Download Center is shown at the right.



Mount the switch on a wall

We recommend that you use the wall-mount screws that are included.

1. Locate the two mounting holes on the bottom panel of the switch.

2. Mark and drill two mounting holes in the wall where you want to mount the switch:

- **GS305E:** The two mounting holes must be 1.81 in. (46 mm) apart, center-to-center.
- **GS308E:** The two mounting holes must be 2.95 in. (75 mm) apart, center-to-center.

3. Insert the supplied anchors into the wall and tighten the screws with a No. 2 Phillips screwdriver.

Leave about 0.12 in. (3 mm) of each screw protruding from the wall so that you can insert the screws into the holes on the bottom panel.

! **NOTE:** The screws are 0.25 in. (6.5 mm) in diameter, 0.63 in. (16 mm) in length.

! **NOTE:** The mounting holes on model GS308E are VESA-compliant. You can obtain a 75 mm VESA-compliant mount and mount the switch to a location other than a wall.

Support and Community

Visit netgear.com/support to get your questions answered and access the latest downloads.

You can also check out our NETGEAR Community for helpful advice at community.netgear.com.

Regulatory and Legal

Si ce produit est vendu au Canada, vous pouvez accéder à ce document en français canadien à netgear.com/support/download/. (If this product is sold in Canada, you can access this document in Canadian French at netgear.com/support/download/.)

For regulatory compliance information including the EU Declaration of Conformity, visit netgear.com/about/regulatory/. See the regulatory compliance document before connecting the power supply. For NETGEAR's Privacy Policy, visit netgear.com/about/privacy-policy.

By using this device, you are agreeing to NETGEAR's Terms and Conditions at netgear.com/about/terms-and-conditions. If you do not agree, return the device to your place of purchase within your return period.

Do not use this device outdoors.

Applicable to 6 GHz devices only: Only use the device indoors. The operation of 6 GHz devices is prohibited on oil platforms, cars, trains, boats, and aircraft, except that operation of this device is permitted in large aircraft while flying above 10,000 feet. Operation of transmitters in the 5.925-7.125 GHz band is prohibited for control of or communications with unmanned aircraft systems.

December 2024



201-31926-01

NETGEAR, Inc.

NETGEAR INTERNATIONAL LTD

© NETGEAR, Inc., NETGEAR and the NETGEAR Logo are trademarks of NETGEAR, Inc. Any non-NETGEAR trademarks are used for reference purposes only.